

Hambro®

D500 COMPOSITE FLOOR SYSTEM

INSTALLATION GUIDE

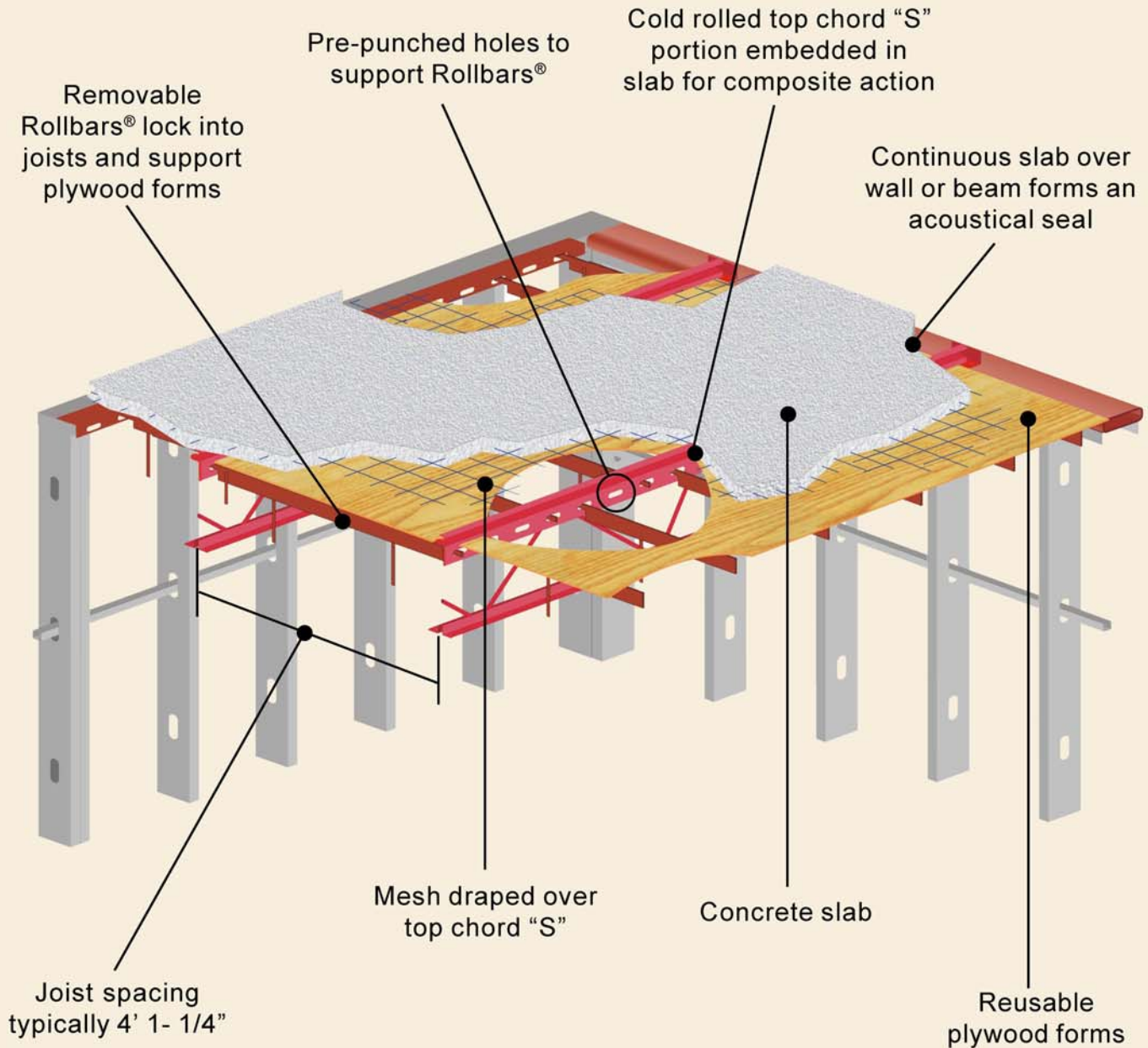
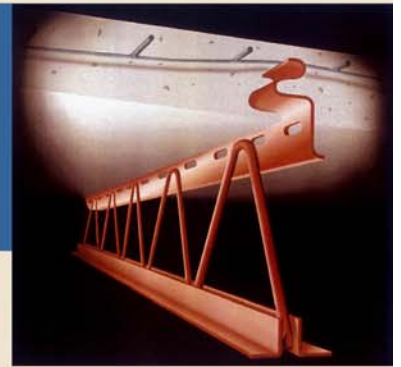

SWIRNOW STRUCTURES LLC
2801 Sisson Street • Baltimore, Maryland 21211-2902
866/388-8833 • Fax: 410/338-1124 • 410/338-1122

www.swirnow.com

Copyright © 2010. All Rights Reserved. Trademarks and Service Marks used under license.

SIX STEPS to a fast & economical installation.



Spreading the Joists: Bundles of joists are placed on walls or beams and spread to approximately 4' o/c. With this greater joist spacing, the number of joists to be handled is reduced - a benefit in joist sorting especially on tight sites where space is limited.



Placing Rollbars®: These secondary members support the forms, slab and construction loads. Rotated and locked into holes in the top chord, Rollbars guarantee exact joist spacing while providing lateral and torsional stability. Typically, no permanent bridging or bracing is required. Bottom chords are fabricated with clips to accommodate a Rollbar for additional bracing as required.



Installing Plywood Forms: The system reuses full sheets of standard 3/8" CDX grade plywood. Plywood is lapped and together with the Rollbars provides a secure platform during construction. Where 1/2" or 5/8" plywood is used, no lapping is permitted.



Mesh in Place: Standard 8' x 20' sheets of mesh are easily placed over top chords of Hambro joists. The mesh drapes and forms a natural catenary to reinforce and support the concrete slab.



Pouring Concrete: Minimum 2-3/4" 3,000 psi monolithic slab forms an acoustical seal where the slab passes over walls. The top chord protrudes into the slab for composite action, and serves as a guide for screeding.



Stripping the Formwork: Rollbars and plywood are stripped, usually the day after the pour or once the concrete reaches 500 psi. The deck is ready for other trades when the concrete reaches a strength of 1,000 psi.

TABLE OF CONTENTS

I.	TOOLS	Page 3
II.	UNLOADING, STORING, AND HANDLING	Page 3
III.	SETTING THE JOISTS	Page 3
IV.	INSTALLING THE ROLLBARS [®]	Page 4
V.	PLACING THE REMOVABLE PLYWOOD FORMS	Page 6
VI.	PLACING THE MESH	Page 7
VII.	PLACING THE CONCRETE	Page 7
VIII.	STRIPPING THE FORMS	Page 9
IX.	CORRECTIVE REMEDIES IN THE FIELD	Page 9

Important Note:

This information is provided as a basic guide of recommended techniques for the typical installation of the Hambro[®] D500 Composite Floor System. It is not intended to take the place of the requirements of applicable building codes. All work must be in accordance with the construction documents and “Field-Use” Drawings for the specific project. Accordingly, while these guidelines are intended as recommended general techniques to be followed, these techniques can be used only to the extent they do not conflict with building code requirements, construction documents and site conditions. You are requested to contact your Hambro[®] representative for conditions not clearly covered in this guide.

Hambro[®] Shop Drawings are provided for the review and approval of the Purchaser, the Architect, and the Engineer of Record to verify and coordinate the joist locations, spans, capacities, loads, details, and to check for correctness in relation to construction documents and specifications. Hambro[®] Shop Drawings are based on the latest information provided to the Supplier which may differ from the contract documents. Hambro[®] Joists are fabricated in strict accordance with the “Field-Use” Drawings, which must always be used in conjunction with the construction documents.

I. TOOLS

1. Large hammer and 2" x 4" for tapping joist shoes for proper bearing, and the forms under the joist seats and beam flanges, if applicable.
2. Circular saw, crowbar, hammers.
3. Minimum two 2' x 6' long rolling scaffolds for Rollbar® installation.
4. (2) 4' pipes for levering tight Rollbars® in and out.
5. Pallet jack, for large floor areas for movement of pallets of Rollbars® and plywood.
6. Form oil and applicator, optional. (*Do not spray the joists or mesh.*)

II. UNLOADING STORING AND HANDLING

Delivery: Hambro® joists will arrive in full tractor-trailer loads banded in nested bundles. Suitable access must be provided so that trucks can move under their own power. Proper equipment must be provided to unload the joists and Rollbars®.

Joist Identification: Hambro® joists are tagged with an identification plate attached at one end on the joist shoe. (Tag End)

Upon delivery, all materials must be crosschecked with the packing list by the buyer and/or erector at the jobsite. All discrepancies and damages must be promptly reported to seller within 48 hours of delivery, otherwise replacement joists will be an additional charge

Storing: The Hambro® joists must be stored upright on a flat surface, and joists should be stacked carefully to prevent damage. Care shall be exercised at all times to avoid damage through careless handling during unloading, storing, and erecting. Time will be saved during the erection process if, while unloading the bundles, they are stacked in some organized fashion, either by mark or floor with tags all facing the same direction.

Hoisting: When hoisted by crane, the cables can be placed at each end or at third points of the joists. Cables must be placed under the top chord and never attached to the web members.

Damaged joists, regardless of the reason, may impair the performance and safety of the system and must be repaired or replaced prior to erection. *DO NOT MAKE FIELD REPAIRS TO ANY DAMAGED HAMBRO® JOISTS WITHOUT WRITTEN APPROVAL FROM YOUR STRUCTURAL ENGINEER AND CONSULTING WITH A QUALIFIED HAMBRO® REPRESENTATIVE.*

III. SETTING THE JOISTS

Typical Spacing: Hambro® joists are typically spaced 4'-1¼" on center (o.c.), but to start the erection procedure, space them at approximately 4' o.c. on the bearing provided.

Five points where extra care should be taken:

1. **Direction of Top Chord:** It is an absolute necessity that all top chords face the SAME DIRECTION within a bay. This is confirmed by joist tag end directions shown on the Shop Drawings. The tag end of the joist will have a small stamped steel tag with the joist mark on it.

As you will note from Diagram #1, forms butt on one side of the top chord, but tuck under on the opposite side. If the joists are not installed as indicated, forms will not fit properly i.e. the forms will be too wide or too narrow to suit the joist spacing.

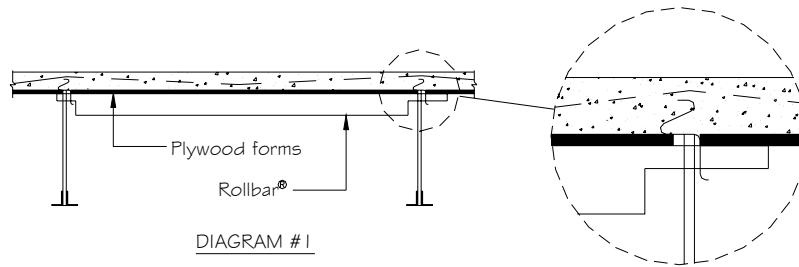

2. **Special joists** (i.e. deep shoes, point loads or Hangerplate™) will determine the direction of the tag end. The direction of the tag ends are shown on the shop drawing. Before you start the installation, determine the proper direction of the tag ends from the shop drawings.
3. **End Joists:** A close measurement should be taken for the first joist that is set, usually the one next to the wall, beam, or tie joist. Careful measurement of this spacing will save unnecessary excessive shifting of the system after all of the joists are set and Rollbars® are in place. All measurements should be taken from the slots of joist top chords.
4. **Bearing:** It is important to make sure that the joist shoes are placed properly on the supporting walls or beams. Joists should be centered between walls or beams so that you get equal bearing for both shoes. Follow the minimum dimensions specified on the "Field-Use" Hambro® Shop Drawing. Unless noted otherwise, the minimum bearing on masonry and wood support is 3½", and 2½" on structural steel. *REDUCED BEARING COULD PRESENT A SAFETY HAZARD.* As soon as the Hambro® joist is installed the Rollbar® shall be installed.
5. **Long Joists:** Pay particular attention to the erection of long Hambro® joists. Joists shall be adequately braced using Rollbars® immediately after setting to prevent lateral movement. The joist must be straight (no sweep) and plumb before placing the concrete.

Important: As soon as the joists are erected, the remaining Rollbars® should be installed.

When bearing on structural steel or steel stud walls, the Engineer of Record may require welding of the joist shoes to restrain the beams or walls.

Warning: Do not weld any Hambro® joist, if required, without first having inserted a Rollbar® at each end and in the center of the joist to assure proper spacing.

IV. INSTALLING THE ROLLBARS®

Slots in the top chord are 5/8" x 1¾" and spaced 7" o.c. The first Rollbars® at the end of the joist, nearest the beam or wall, must be installed with the clip angles on the Rollbars® facing the wall or beam. They can only be removed by rotating the handles away from the wall and the clip angles pivoting away from the bottom of the plywood form.

ROLLBARS®: Note the various types and their specific purpose. Rollbars® are delivered F.O.B. the jobsite, by Supplier, for your use. The Purchaser must have suitable equipment on site to both load and unload the Rollbars® on and off the Supplier's truck.

Standard Rollbar® (SRB) is used for typical 4'-1¼" joist to joist, joist to Flangehanger™ spacing. Also available in 5'-0" and 5'-¼" lengths.

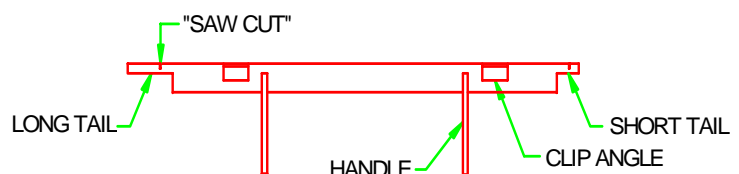

STANDARD ROLLBAR® - SRB

Extension Rollbar® (ERB) is adjustable for joist to joist, and joist to Flangehanger™ spacing. Small ERB from 1'-10¾" to 3'-1". Large ERB from 3'-1" to 4'-7".



EXTENSION ROLLBAR® - TRB2 OR TRB3

Telescopic Rollbar® (TRB) has a short tail on one end and a flat arrow tip on the other end for joist to ledger spaces only. 2'-8" to 4'-7".

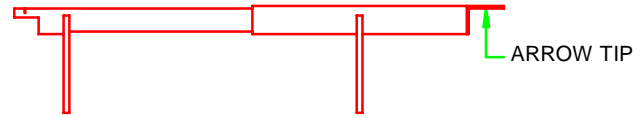

TELESCOPIC ROLLBAR® - TRB1

Flangehanger™ is a 13-gauge angle shipped in 20' lengths. Flangehanger™ is an optional accessory that is provided only when specifically ordered. The Flangehanger™ has slots in the vertical leg which correspond to the slots in the Hambro® joist top chord. Flangehanger™ is field cut to length for attachment to steel beams which are parallel to the joists. It can be welded or power shot to the flange of parallel beams. Once the Flangehanger™ has been securely attached, the Rollbars® can be supported by the beams. **NOTE: Flangehanger™ is attached ONLY TO BEAMS WHICH ARE PARALLEL to the Hambro® Joists and remains permanently attached to the beam.**

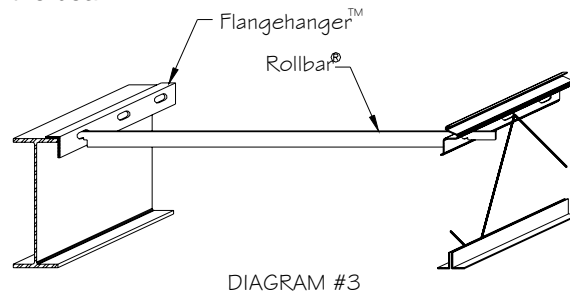

DIAGRAM #3

Spacing: The Hambro® joist top chord has pre-punched holes every 7". In order to support forms properly, care should be taken to install the Rollbars® at 21" o.c. (every third hole), for the usual 2¾" to 3½" slab. Exceeding this dimension would be dangerous, since it overloads the Rollbars® and plywood. IMPROPER SPACING OF ROLLBARS® MAY AFFECT THE STRUCTURAL SAFETY OF THE SYSTEM DURING THE CONCRETING STAGE. There should be a Rollbar® 7" from the end of each plywood form.

Thickened Slabs: In the areas where thicker slabs are specified, Rollbars® should be placed at closer intervals. Where certain areas have been thickened or Hangerplate™ is used, Rollbars® should not be spaced more than 14" o.c. for slabs 3¾" to 6" thick and 7" o.c. for slabs exceeding 6" thickness.

Stagger Rollbar® spacing from bay to bay whenever possible to avoid having two Rollbar® ends in the same slot. This will simplify the stripping procedure. This does not apply to the temporary bottom chord bracing or the first Rollbar® nearest the supporting beam or wall.

Sequence of Installation: Standard Rollbars® should be installed first, starting with the ends of the first two joists in the bay, and working toward the middle of the bay. Install the Telescopic Rollbars® last.

Temporary Bottom Chord Bracing: To provide additional stability during concreting, Rollbars® shall be inserted in the clips that are welded to the bottom chords of the joists. This temporary bracing is removed when stripping the forms, as it is not required at the composite stage. At the end of each joist run, bottom chord bracing must be firmly braced to stable walls, or beams or main structural frame and be firmly attached at both ends. In the absence of stable walls or beams, "X" bracing must be used. (See Diagram #4.) "See plans for location of temporary bottom chord bracing.

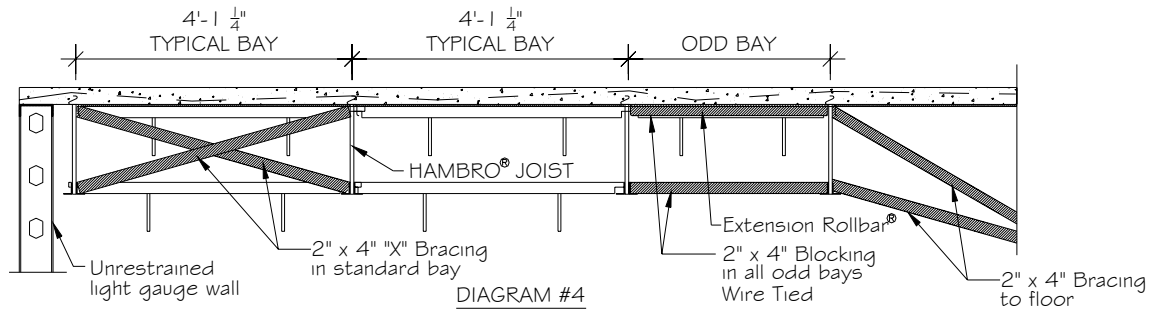

CAUTION:

To prevent lateral movement of the top chords during construction, the lateral support provided by regular 4'-1 1/4" slotted Rollbars® must be carried on right through to the end walls or beams. Where TRB's have been used between joists (odd spacing), positive spreaders must be spaced at 1/4 points (i.e., a 2" x 4" cut to exact length). Note: Plywood forms ripped to the exact width will help provide the required lateral support.

NOTE: Bracing must be continuous at bottom chords during construction to ensure that all joists remain vertical. At end joists, where no wall or structural frame is present, brace bottom chord to the floor or grade.

NOTE: For smaller than "standard bays" but greater than 2'-8" (Diagram #5), you should use the Telescopic Rollbars® supplied to support the forms. Caution: Telescopic Rollbars® should never be placed on top of a wall or beam as the form will be at the wrong elevation and encroach into the slab thickness in that area. Telescopic Rollbars® should always be placed on ledger strips. On steel frame projects, Flangehanger™ placed on top of the beam flange proves to be a time saver. Only Extension and Standard Rollbars® can be used with Flangehanger™. Note: for joist spacing up to 1' 9 3/4" and less (Diagram #6), #4 rebar should be used to support the forms (supplied by installer).

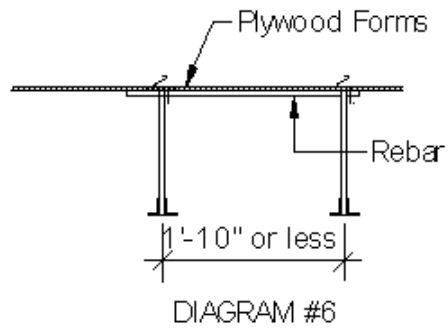
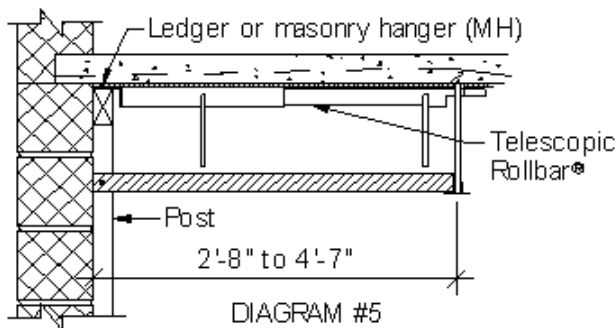

IMPORTANT NOTICE: The Rollbars® shipped to the site are either new or used. During the course of the project, the Rollbars® may be bent. All workmen should be informed of the importance of a proper and improper bow in the Rollbars®. A Rollbar® which has rotated out of plumb has virtually no capacity to support the construction loads and is an unsafe condition.

V. PLACING THE REMOVABLE PLYWOOD FORMS

Plywood Type: The standard spacing (4'-1 1/4") is designed to accept a standard 4' x 8' sheet of CDX 3/8" or 1/2" plywood. When using a 3/8" sheet of plywood, the forms are to be overlapped at least 12". When using 1/2" plywood, all joints should be butted since the thickness would encroach into the area of the top chord that is designed to be imbedded into the concrete. When the choice is available, you will find it more economical to use 3/8" plywood and "lap the joints".

End Bay Condition: When placing the plywood forms next to the end joist, be sure to avoid having the plywood sit on the bearing wall or beam. You will find that a plywood form bonded between the concrete pour and the bearing wall or beam, is no longer removable and has to be chopped out.

NOTE: In order to take advantage of the system's flexibility, it is recommended that the builder and other subcontractors check the position of the joists in relation to any risers and slab openings, etc., which will be coming through the deck prior to placing the forms in the end bays. At this point, before end bays are formed, in most cases, the entire deck can be shifted a few inches in either direction. Check and adjust joist spacing if necessary.

Oiling plywood is not required, however, it will save labor in stripping and will prolong the useful life of the forms. Forms are ordinarily stripped the day following the pour, provided the concrete strength has reached 500 psi. **DO NOT OIL THE JOISTS OR MESH.**

Slab Penetrations are achieved by attaching the desired size sleeve directly to the plywood. Foam blocks or short lengths of pipe are commonly used. After the slab is poured, the forms are removed with the plywood. Openings greater than 8"x 8" require double mesh and possibly rebar. Avoid placing openings closer than 6" to the joist top chord so as not to interfere with the composite action. Refer to structural drawings for reinforcement at openings and clear distance to joists.

CAUTION:

1. Bundles of plywood, mesh or Rollbars® should be placed on supporting walls or beams, never on the joist system. The system is not designed for this condition and will present a serious safety hazard, along with damage to the joists. Break down all bundles to ensure load distribution in accordance with design loads at all times.
2. Before any load is imposed on joists and prior to the plywood forms being installed, there should be at least four joists bays completed with standard Rollbars® including the temporary bottom chord bracing installed to safely develop the structural non-composite capacity of the Hambro® joists.
3. Full sheets of plywood are recommended. When shorter pieces are used, make sure they are adequately lapped and supported and safe for workers and construction loads.

VI. PLACING THE MESH

Flat sheets of welded wire mesh are recommended in lieu of rolled mesh for its ease of handling, and because it lays more naturally without the ends sticking up. The flat sheets are laid across the joists with the long dimension running from joist to joist.

Lapping: Be sure to get the minimum lap of 6" perpendicular to joists and 12" lap parallel to joists. Be sure the mesh extends onto the perimeter beams or walls at least 4" in order to develop the capacity of the slab.

Unless otherwise noted on the "Field-Use" Drawings, a single layer of mesh is all that is typically required. On the Hambro® Shop Drawings, a hatched area indicates two layers of mesh.

Always check the final construction documents or approved erection drawing for the proper reinforcement and mesh type and follow the construction drawings for the placement of slab reinforcement.

The flat sheets of mesh should drape naturally. Do not step down the mesh on either side of the top chord.

VII. PLACING THE CONCRETE

Concrete Note: When estimating the concrete volume, assume a coverage of approximately 99sf per cubic yard for a 2¾" slab. This takes into account the minor variation in slab thickness due to the lapping of the formwork and a nominal amount of waste. Additional material should be added for thickened areas, cantilevered slabs or special conditions as required. ***The Supplier is not responsible for variations in material or labor costs.***

Concrete Mix: The minimum concrete compressive strength is 3,000 psi. The aggregate in the concrete mix should not be greater than ¾".

Screeding: When screeding, maintain a minimum depth of 1¼" above the top chord for a nominal 2¾" slab. You will notice that the joists are fabricated with a positive camber to offset the deflection caused by the weight of the concrete. It will come out as the slab is poured, leaving a small residual camber for the remaining design load.

Slump: Field experience has shown that a 3½" to 4½" slump is easy to work with and finish. Greater slumps will create excessive leakage and costly clean up. Refer to the Structural Drawings and Project Specifications for requirements.

CAUTION: Too high a slump reduces the strength of the concrete and causes excessive shrinkage cracks. Curing procedures should be in accordance with the latest ACI requirements.

Vibrating: The concrete is to be lightly but thoroughly vibrated to ensure:

1. The full encasement of the top chord in the concrete (letting the vibrator hit the top chord will assure encasement). This is very important to obtain the full design capacity of the system.
2. Elimination of "honeycombs".
3. The concrete is vibrated under the mesh to achieve proper concrete cover.

Construction Joints: When pouring and finishing a deck, it is not necessary to complete the entire deck monolithically. If it becomes necessary to stop the pour parallel to the joists, the joint should be midway between the joists, but never closer than 6" to the top chord. The mesh must extend at least 12" beyond the break. If you stop a pour perpendicular to the joists, locate the joint over the supporting walls or beam.

SAFETY PRECAUTIONS WHEN POURING CONCRETE:

Several simple precautions must be followed before and during the concrete pour to ensure a safe operation:

1. Assign a man below during the pour to check that all Rollbars[®] remain in proper position during the pour. Prevent others from working under the deck when pouring concrete.
2. As previously mentioned, Rollbar[®] spacing should be reduced if slabs thicker than 3½" are to be poured, or joist spacing exceeds 4'-1¼".
3. Check that plywood forms are properly lapped or butted, and that they have not moved sideways into the top chord.
4. During the pour, care should be taken not to subject the joists to excessive construction loads or the performance and safety of the system may be impaired. Do not pour concrete in excess of slab thickness specified on drawings, and do not drop large bucket loads or pump excessive concrete in a concentrated area.

5. The pre-punched holes in the top chord section and the Rollbars® are not designed to support buggies; therefore, runways must be placed across the top chord. This is usually accomplished with wood planks, laid perpendicular to the joists.
6. **CAUTION:** Do not overload the slab or joists at any phase of construction.

VIII. STRIPPING THE FORMS

At such time as the concrete reaches a cylinder strength of 500 psi, the Rollbars® and plywood forms can be stripped. The concrete deck is ready for work when the cylinder strength reaches 1,000 psi.

Avoid dropping Rollbars® on slab, as this may cause chipping of the concrete surface. Avoid dropping the plywood forms when stripping. This causes damage to corners and edges and reduces the amount of re-use.

After stripping, Rollbars® should be neatly stacked parallel to each other on a pallet before transporting.

- A. Care should be exercised not to overload the system; pallets of block and bundles of mesh, plywood or gypboard should be placed over supporting walls or beams or spread out when placed on the slab.
- B. **DO NOT MODIFY OR ALTER ANY HAMBRO® PRODUCT WITHOUT FIRST OBTAINING WRITTEN APPROVAL FOR THE DESIRED CHANGE FROM THE STRUCTURAL ENGINEER, AND GUIDANCE FROM A QUALIFIED HAMBRO® REPRESENTATIVE.**
- C. Similarly, if it becomes necessary to deviate from the "Field-Use" Hambro® Shop Drawings supplied with each job, obtain approval of the structural engineer prior to making that change.
- D. When core drilling a slab, avoid drilling within 6" of a joist. Openings 8" x 8" or larger require double mesh and possibly rebar. Consult the structural engineer. Refer to structural drawings for reinforcement at openings and clear distance to joists.
- E. In the event a joist is damaged, by whatever cause, obtain written approval from the project structural engineer before it is used. Replace joists as directed by the Engineer of Record.
- F. In hot, sunny weather, to precaution to wet down the deck with water to prevent the concrete from setting too rapidly, which may cause excessive shrinkage cracks to appear. Always follow ACI requirements.

IX. CORRECTIVE REMEDIES IN THE FIELD

There are certain conditions that, in some instances, appear and are not to be considered "manufacturing defects". Because of Hambro's® simplicity, they are corrected in the field as a standard procedure by the installer. All corrective measures shall be subject to the Engineer of Record's approval prior to implementation.

- A. Joist Sweep: Occasionally, some Hambro® joists may exhibit excessive sweep. This condition is easily corrected as a standard procedure of the installer at the job site. In the few instances where necessary, simply lay the joist on its side, supported at each end. The weight of one or two workmen standing on the joist will usually correct this sweep. Minimal sweep is nothing to be concerned with, as long as there are relatively straight joists at the beginning of the installation. The continued application of Rollbars® will then further straighten successive joists that may have minimal sweep. No concrete shall be poured on any decks where joist sweep exceeds manufacturer's tolerances.
- B. Bent Shoes: Bent shoes which are no longer 90° to the plane of the web are corrected by simply hammering them level or by merely shimming the out-of-level areas so as to plumb the joist and obtain adequate bearing. The grout in the concrete mix will readily run under the shimmed shoes. Shimming should be done using metal.

Hambro®



The Floor System That Gives You Every Advantage

- ■ OPEN WEB JOIST CONFIGURATION, NO BRIDGING, AND 4' JOIST SPACING accommodates mechanical distribution within the joist plenum; permits full lengths of duct and water pipe, reducing the many connections when using shorter lengths. Virtually eliminates dropped ceilings and soffit enclosures.
- ■ REDUCES BUILDING HEIGHT and develops savings in the cost of skins and all other vertical components.
- ■ SHALLOWER JOISTS WITH RIGIDITY AND STIFFNESS; HAMBRO® composite design generally saves 2 to 4 inches against conventional joist systems. Hambro® slabs key into voids in block and encase top flange of interior beams, develops diaphragm action and ties the structure together.

- ■ VERY WELL SUITED FOR WOOD, STEEL STUD, STEEL, AND CONCRETE FRAMES.
- ■ U.L. DESIGNS FOR 1, 2, AND 3 HOURS with gypsum board, spray fire-proofing or acoustical tile. One layer of fire code gypsum screw attached to furring channels spaced 2' o.c. provides up to 3 hours of protection. For up to 1-1/2 hours, U.L. designs permit UNPROTECTED CEILING PENETRATIONS of up to 196 sq. in. per 100 sq. ft. of ceiling area (2 hours permits 100 sq. in.)... eliminating fire dampers or protection at ceiling openings.
- ■ STC 57 ON BARE CONCRETE.
- ■ SLAB PENETRATIONS ARE EASY using either sleeves, styrofoam or wood blocking prior to concreting. No metal decking to cut or tendons to be concerned with. Fewer joists offer flexibility. Slender 3,000 psi slab makes coring simpler, if necessary.

Approvals

The Hambro® D500 Composite Floor System has been approved, listed, classified, recognized, certified, and/or accepted by the following leading national and local building codes and authorities:

- Building Officials Code Administrators (B.O.C.A.)
- Underwriters Laboratories, Inc. designs for 1, 2, and 3 hour fire ratings
- Southern Building Code Congress International (S.B.C.C.I.)
- International Conference of Building Officials (I.C.B.O.)
- Housing & Urban Development-Federal Housing Administration (HUD-FHA)
- Metropolitan Dade County Building Code
- New York City; Philadelphia; Baltimore; Washington, DC; Fairfax County; etc.
- U.S., Canada and Foreign patents around the world



SWIRNOW STRUCTURES LLC
2801 Sisson Street • Baltimore, Maryland 21211-2902
866/388-8833 • Fax: 410/338-1124 • 410/338-1122
www.swirnow.com

Copyright © 2010. All Rights Reserved. Trademarks and Service Marks used under license.